



ECOSURFACES ROLLS, TILES & PAVERS

INSTALLATION AND MAINTENANCE MANUAL

Manufactured in the U.S.A. by:

ecore

Revised on 02/26/2016
Supersedes all previous versions.
Check website for updates.

TABLE OF CONTENTS

INSTALLATION

Job Site Conditions	2
Subfloors	2
Subfloor Preparation	2-4
Storage & Handling	4-5
Roll Installation	4-8
Tile Installation	8-10
ECO [®] pave Installation	11-14
ECO [®] comfort Installation	15

MAINTENANCE

Floor protection	16
Assignment of Cleaning	16
Cleaning Chart Uncoated	17
Cleaning Procedures Uncoated	17-18
Cleaning ECO [®] PAVE	19
ECOGUARD INSTRUCTIONS	20-26
ECOGUARD Questions & Answers	26

WARRANTY

WARRANTY	27
----------	----

INSTALLATION

I. JOB SITE CONDITIONS

- A. Installation should not begin until after all other trades are finished in the area. If the job requires other trades to work in the area after the installation of the floor, the flooring should be protected with an appropriate cover.
- B. Areas to receive flooring should be weather tight and maintained at a minimum uniform temperature of 65° F (18° C) for 48 hours prior to, during, and after installation.

II. SUBFLOORS

ECOSurfaces and ECOcomfort rolls and tiles may be installed over concrete, approved Portland based self-leveling materials, such as Ardex K-15 or equivalent, and wood.

Note: Ardex Engineered Cements
400 Ardex Park Drive
Aliquippa, PA 15001
(724) 203-5000

Note: Gypsum based patching and leveling compounds are not acceptable.

- A. Wood Subfloors: Wood subfloors should be double construction with a minimum thickness of 1". The floor must be rigid, free from movement, and have at least 18" of well-ventilated air space below.
- B. Underlayments: The preferred underlayment panel is APA underlayment grade plywood, minimum thickness of 1/4", with a fully sanded face.

Note: Particle board, chip board, Masonite, and lauan are not considered suitable underlayments.

- C. Concrete Floors: Concrete shall have a minimum compressive strength of 3000 psi. It must be fully cured and permanently dry.

III. SUBFLOOR REQUIREMENTS AND PREPARATION

- A. Subfloor shall be dry, clean, smooth, level, and structurally sound. It should be free of dust, solvent, paint, wax, oil, grease, asphalt, sealers, curing and hardening compounds, alkaline salts, old adhesive residue, and other extraneous materials, according to ASTM F710.
- B. Subfloor should be smooth to prevent irregularities, roughness, or other defects from telegraphing through the new flooring. The surface should be flat to the equivalent of 3/16" (4.8 mm) in 10 feet (3.0 m).
- C. Mechanically remove all traces of old adhesives, paint, or other debris by scraping, sanding, or scarifying the substrate. Do not use solvents. All high spots shall be ground level and low spots filled with an approved cementitious based patching compound.
- D. All saw cuts (control joints), cracks, indentations, and other non-moving joints in the concrete must be filled with an approved cementitious based patching compound.

INSTALLATION

- E. Expansion joints in the concrete are designed to allow for expansion and contraction of the concrete. If a floor covering is installed over an expansion joint, it more than likely will fail in that area. Expansion joint covers designed for resilient floor coverings should be used.
- F. Always allow patching materials to dry thoroughly and install according to the manufacturer's instructions. Excessive moisture in patching material may cause bonding problems or a bubbling reaction with the E-Grip III™ adhesive.

HAZARDS:

SILICA WARNING - Concrete, floor patching compounds, toppings, and leveling compounds can contain free crystalline silica. Respirable crystalline silica (particles 1-10 micrometers) can be produced by cutting, sawing, grinding, or drilling. Respirable silica is classified by OSHA as an IA carcinogen and is known to cause silicosis and other respiratory diseases. Avoid actions that cause dust to become airborne. Use local or general ventilation, or protective equipment, to reduce exposure below applicable exposure limits.

ASBESTOS WARNING - Resilient flooring, backing, lining felt, paint, or asphaltic "cutback" adhesives can contain asbestos fibers. Avoid actions that cause dust to become airborne. Do not sand, dry sweep, dry scrape, drill, saw, beadblast, or mechanically chip or pulverize. Regulations may require that the material be tested to determine asbestos content. Consult the documents titled, "Recommended Work Practices for Removal of Existing Resilient Floor Coverings," available from the Resilient Floor Covering Institute.

LEAD WARNING - Certain paints can contain lead. Exposure to excessive amounts of lead dust presents a health hazard. Refer to applicable federal, state, and local laws and the publication, "Lead Based Paint: Guidelines for Hazard Identification and Abatement in Public and Indian Housing," available from the United States Department of Housing and Urban Development.

- G. Maximum moisture vapor emission of the concrete must not exceed 5.5 lbs. per 1000 square feet in a 24 hour period, as measured by the calcium chloride moisture emission test conducted in accordance to ASTM F1869. Moisture can also be measured using the RH Relative Humidity test method per the ASTM F2170 standard. Moisture content should not exceed 85% RH. If levels are higher using either test method, then one of Ecore's recommended vapor retardants must be used. If the emissions exceed the limitations, the installation should not proceed until the problem has been corrected.

NOTE: For moisture remediation, Ecore recommends the following two vapor retardants.

1. ARDEX MC Rapid, Plus or Ultra – 724-203-5000, www.ardex.com
2. Bostik Durabond D-250 – 888-592-8558, www.bostik-us.com

INSTALLATION

- H. It is essential that pH tests be taken on all concrete floors. If the pH is greater than 9, it must be neutralized prior to beginning the installation.
- I. Adhesive bond tests should be conducted in several locations throughout the area. Glue down 3' x 3' pieces of the flooring with the recommended adhesive and trowel. Allow to set for 72 hours before attempting to remove. A sufficient amount of force should be required to remove the flooring, and there should be adhesive on the subfloor and the back of the flooring.

IV. Material Storage and Handling

- A. Material should be delivered to the job site in its original unopened packaging with all labels intact.
- B. Roll material should always be stored lying down. Storing rubber on end will curl the edges, resulting in permanent memory of the material. Do not store rolls higher than 4 rolls or for more than 6 months.
- C. All edges with memory curl should be straight cut before installation. In some instances it may be necessary to weigh down the seam until adhesive develops a firm set.
- D. Inspect all material for visual defects prior to beginning the installation. No labor claim will be honored on material installed with visual defects. Verify the material delivered is the correct style, color, and amount. Any discrepancies must be reported immediately before beginning installation.
- E. The material and adhesive must be acclimated at room temperature for a minimum of 48 hours before starting installation.

NOTE: ECOsurfaces flooring is manufactured from recycled materials and slight variance in shade and color chip dispersion is normal. It is the installer’s responsibility to inspect all products to ensure the correct style, thickness, and color. Any moderate to severe discrepancies should be reported immediately before beginning installation.

- F. All ECOsurfaces rolls must be unrolled and installed in the same direction (directional arrows are stamped on bottom of the rolls). ECOsurfaces tiles must also be installed in the same direction (arrows on the bottom must be pointing in the same direction). Rolls are labeled with batch numbers and roll numbers. Do not mix batch numbers together and install all rolls in consecutive order. (See diagram 1.)

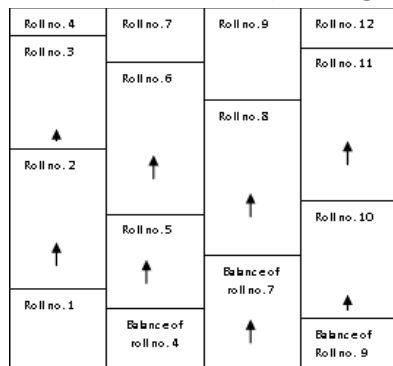

INSTALLATION

G. Roll material is stretched slightly when it is rolled at the factory. At the job site, the installer should allow all rolls to relax for a minimum of two hours before gluing or cutting material.

V. INSTALLATION - SHEET 3.2mm and 6mm only. (8mm and 9mm skip to G.-2. Page 7)

A. Cut the first sheet at the required length, including enough to run up the wall and overlap for seaming at each end.

B. Position the first sheet against the wall and square with the room.

C. Cut second sheet with proper extra length.

D. **Position second sheet with required overlap over the first roll at the seam.**

Each 48" roll must be overlapped by 2" and 51" rolls must be overlapped by 5" minimum.

Failure to comply with required overlap could result in shade variance between rolls.

IMPORTANT - Overlap amount is dependent upon the width of material provided.

Please refer to seaming method diagrams for proper overlap amounts required.

E. Repeat for each consecutive sheet necessary to complete the area or those rolls that will be installed that day.

F. Allow the rough cuts to relax in position for a minimum of 2 hours before double cutting seams and applying the adhesive.

G. SEAMING METHODS 3.2mm and 6mm only. (8mm and 9mm skip to Page 6)

1. 1/4" (6mm) and thinner: Place a 4" wide scrap of material under the seam area. Using a straight edge and new razor blade, hold the knife straight up and down and cut through both pieces in one cut.

NOTE: Each 48" wide roll must be overlapped by 2" and 51" rolls must be overlapped by 5" minimum.

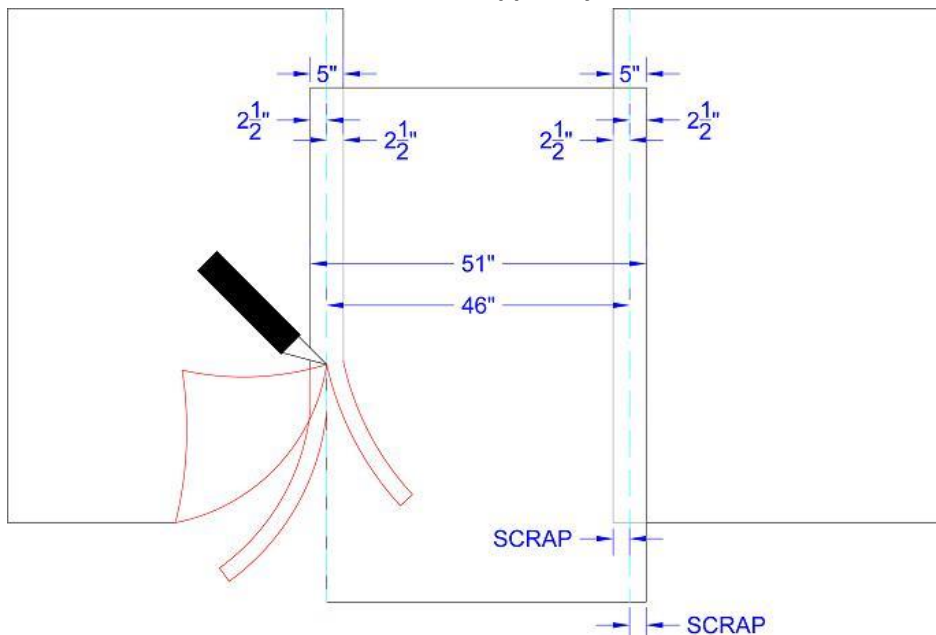

51" Wide Rolls must be overlapped at a minimum of 5"

INSTALLATION

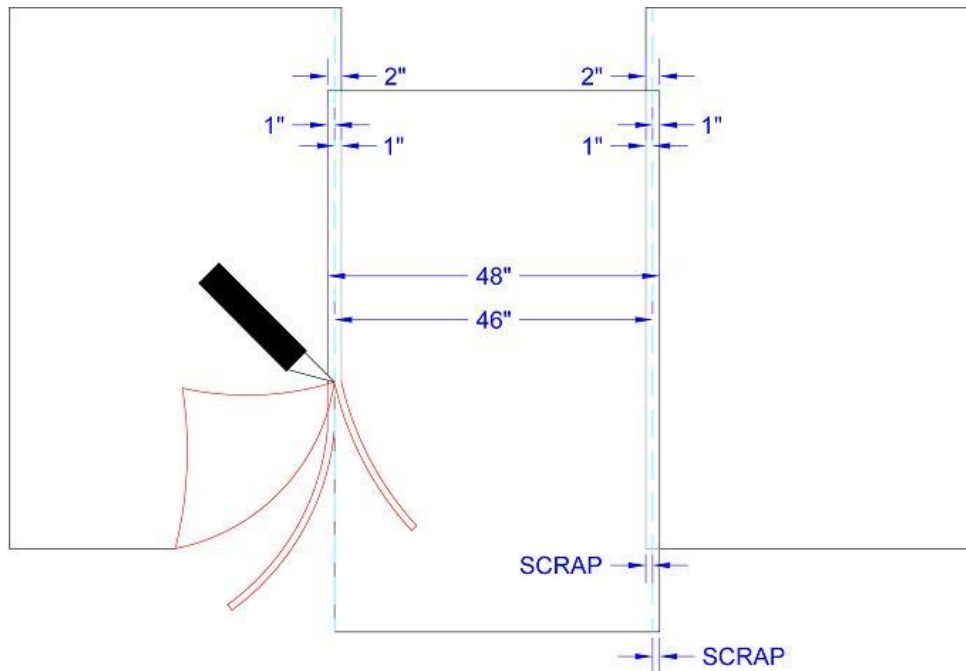

48" Wide Rolls must be overlapped at a minimum of 2"

2. 8mm and thicker material
 - a) Make the assumption that the walls you are butting against are not straight or square. Using a chalk line, make a starting point for an edge of the flooring to follow. The chalk line should be set where the first seam will be located.
 - b) Remove the Everlast from the shrink wrap and unroll it onto the floor. Lay the rubber on the floor in a way that will use your cuts efficiently. Cut all rolls at the required length, including enough to run up the wall a few inches.
 - c) If end seams are necessary, they should be staggered on the floor and overlapped approximately 3-6". End seams will be trimmed after acclimation period, using a square to ensure they fit tightly without gaps.
 - d) Allow the rough cuts to relax in position for a minimum of two hours. 24 hours is preferred.
 - e) After allowing the flooring to relax, you may begin the installation.
 - f) Align the first edge to the chalk line.

Note: it is very important the first seam is perfectly straight.

- g) Position the second roll with no more than a 1/8" overlap over the first roll at the seam. After adhesive is applied to substrate, the material will be worked back to eliminate the overlap. This procedure will leave tight seams and eliminate any gaps.

INSTALLATION

- h) Care should be taken to not over compress the seam. Over compressed seams will cause peaking.

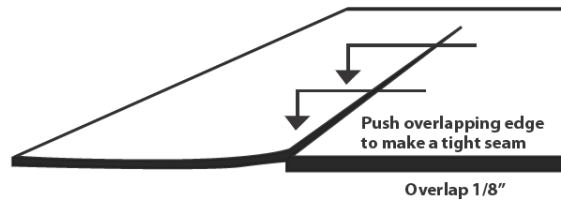

diagram 3

- i) It may be necessary to trim the edge of the second lineal drop, if the rolls do not extend the length or width of the room. Rolls laid end-to-end with a variance in roll width greater than $\frac{1}{4}$ " could result in peaked seams.
- j) Repeat for each consecutive sheet necessary to complete the area or those rolls that will be installed that day.

VI. ADHESIVE APPLICATION

- A. After all above procedures are performed, begin application of Ecore's E-Grip III, making sure to use the proper recommended trowel size:

3.2mm – $\frac{1}{16}$ " x $\frac{1}{32}$ " x $\frac{5}{64}$ " U-Notched Trowel
 6mm – $\frac{1}{16}$ " x $\frac{1}{16}$ " x $\frac{1}{16}$ " Square Notched trowel
 8mm – $\frac{1}{16}$ " x $\frac{1}{16}$ " x $\frac{1}{16}$ " Square Notched Trowel

- B. Fold the first drop lengthwise (half the width of the roll).
 C. Spread adhesive using the proper notched trowel. Take care not to spread more E-Grip III than can be covered by flooring and rolled within 30 minutes. The open time of the adhesive is 30 - 40 minutes at 70° F and 50% relative humidity.

Note: The open time of adhesive is affected by temperature and humidity. High temperatures and high humidity will cause the adhesive to set quickly. Low temperatures and low humidity will cause adhesive to cure at a slower rate. The installer should monitor on-site conditions and adjust open time accordingly.

- D. Carefully lay the material into the wet adhesive. DO NOT let the material drop, because this will cause air to be trapped beneath the flooring.
 E. Immediately roll the floor with a 75 pound or 100 pound roller to ensure proper transfer of adhesive. Overlap each pass of the roller by 50% of the previous pass to ensure that the floor is properly rolled. Roll the width first, then the length. Re-roll again after 30-45 minutes.
 F. Fold over second half of first roll and half of second sheet. Spread adhesive. At seam area spread adhesive at 90 degrees to seam to eliminate excessive adhesive oozing up at seam.

INSTALLATION

- G. In some instances it may be necessary to weigh down the seam until the adhesive develops a firm set. Boxes of cove base or tile work well.
- H. Continue the process for each consecutive drop. Always work at a pace so you are always folding material back into wet adhesive.

NOTE: Never leave adhesive ridges or puddles, they will telegraph through the material.

- I. Do not allow E-Grip III to cure on your hands or the flooring. Cured adhesive is very difficult to remove. We strongly suggest wearing gloves while using E-Grip III. Immediately wipe off excess adhesive with a rag slightly dampened with mineral spirits. Follow the mineral spirits with a rag dampened with water to remove the mineral spirits.

NOTE: Use mineral spirits sparingly. Saturating the rubber with mineral spirits may cause the adhesive to be pushed too deeply into the pores of the rubber.

- J. Hand roll all seams after the entire floor has been rolled. If some seams are gapping, it is possible to hold them together temporarily with blue painters tape. Tape should be removed after adhesive has developed a firm set (approximately 2-3 hours). Allowing tape to remain longer than 2-3 hours or using aggressive tapes may result in adhesive residue. Ecore will not be responsible for residue left behind from tape of any kind.
- K. After you've rolled the floor, keep all foot traffic off the floor for a minimum of 24 hours. Foot traffic and rolling loads can cause permanent indentations or bubbles in the uncured adhesive.

VI. INSTALLATION - TILES

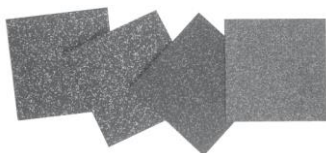

- A. Inspect tiles for visual defects, including shade variances prior to beginning the installation. No labor claim will be honored on material installed with visual defects. Any moderate to severe discrepancies should be reported immediately before beginning installation.
- B. ECOsurfaces tiles are manufactured from recycled materials and slight variance in shade and color chip dispersion is normal. It is the installer's responsibility to lay out tiles prior to installation and inspect them to ensure correct style, thickness, and color.
- C. Tiles manufactured from mats are intended for smaller installations. Larger quantities resulting in multiple dye lots may not be an exact match in shade or density. Every effort is made to ensure the best possible match; however, Ecore makes no warranty on the exact match between dye lots.
- D. All ECOsurfaces tiles must be installed from the same product group. Mixing multiple patterns may result in the installation to be thrown out of square. All tiles are marked on the bottom with arrows. Failure to install directionally will result in an out of square installation.

INSTALLATION

- E. Please contact Ecore Technical Services Department for clarification at 877-258-0843, before beginning the installation.
- F. Measure the width of the area to be covered.
- G. Mark the center of the area at two points, one at each end.
- H. Snap the chalk line, line #1, through these two points.
- I. Determine the center point of the chalk line.
- J. Using a Carpenter’s square or another method, snap a second chalk line, line #2, perpendicular (at 90 degrees) to the first line. The lines should intersect at their centers.

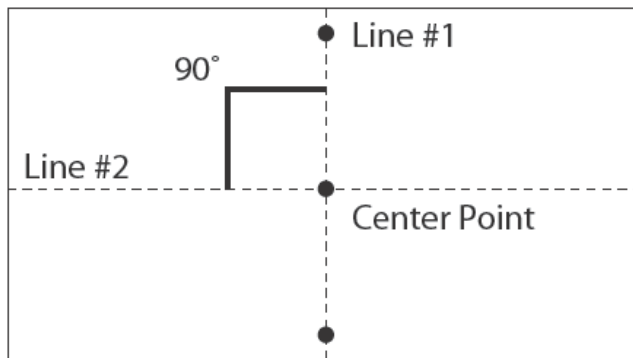

diagram 5a

- K. The area to be covered is now divided into quarters. Begin the installation at the center of the area, where the two lines intersect.

Note: To lay tiles in an ashlar configuration, snap a third chalk line perpendicular to line #2 and parallel to line #1. The distance between line #1 and line #3 should be 1/2 the width of the tile (12 inches). (See diagram 6.)

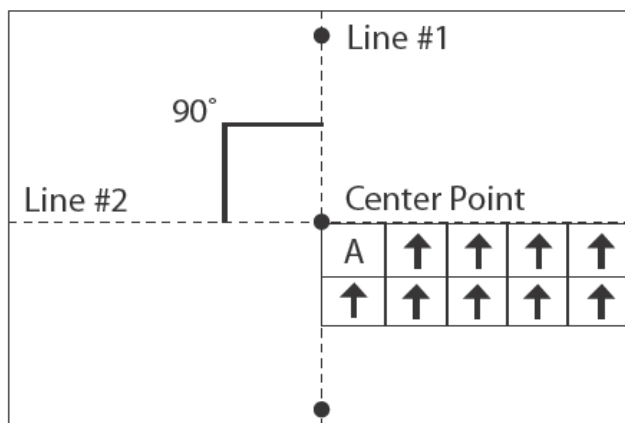

diagram 5b

INSTALLATION

- L. After all above procedures are performed, begin application of Ecore’s E-Grip III, making sure to use the proper recommended trowel size.

3.2mm – 1/16” x 1/32” x 5/64” U-Notched Trowel
 6mm– 1/16” x 1/16” x 1/16” Square Notched trowel
 8mm– 1/16” x 1/16” x 1/16” Square Notched Trowel

- M. Take care not to spread more adhesive than can be covered by flooring and rolled within 30 minutes.
- N. Place the first tile, A, into the wet adhesive, making sure that the edges are precisely placed along the chalk lines and where they intersect. Press firmly on the tiles to remove any curls or entrapped air. **Do not try to stretch or compress fit the tiles.** (See diagrams 5b and 6.)

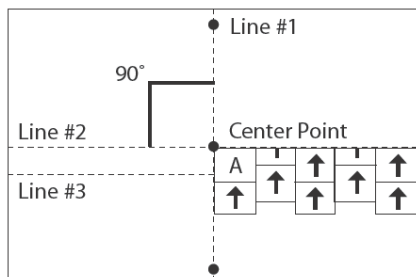

diagram 6

Reminder: Arrows on bottom of tiles must point in the same direction.

- O. Lay whole tiles from left to right along chalk line #1 up to the wall on the opposite side of chalk line #2. The last tile will likely have to be cut to fit against the wall.
- P. Do not allow E-Grip III to cure on your hands or the flooring. Wipe off excess adhesive with a rag dampened with mineral spirits! Cured adhesive is very difficult to remove from hands.

NOTE: Use mineral spirits sparingly. Saturating the rubber with mineral spirits may cause the adhesive to be pushed too deeply into the pores of the rubber.

- Q. Continue this process with each row until you reach the wall across from chalk line #1.
- R. Go back and fill in gaps between the two original chalk lines and the wall on those two sides.
- O. If some seams are gapping, it is possible to hold them together temporarily with blue painters tape. Tape should be removed after adhesive has developed a firm set (approximately 2-3 hours). Allowing tape to remain longer than 2-3 hours or using aggressive tapes may result in adhesive residue. Ecore will not be responsible for residue left behind from tape of any kind.
- P. Roll a 75 pound or 100 pound roller over the floor within 45 minutes to ensure proper transfer of adhesive. Overlap each pass of the roller by 50% of the previous pass to ensure that the floor is properly rolled. Re-roll again after 30-45 minutes.
- Q. Keep foot traffic off the floor for a minimum of 24 hours. Foot traffic and rolling loads can cause permanent indentations in the uncured adhesive and cause tiles to shift.

INSTALLATION

VII. ECOPAVE MOLDED TILES

NOTE: All ECOpave products are to be installed over a solid substrate.

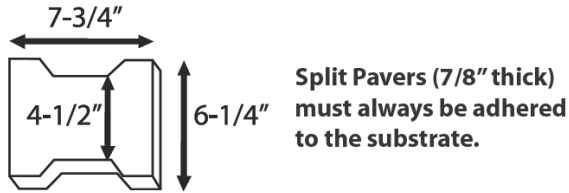

Full Pavers (1-3/4" thick) may be adhered or loose-laid. If loose-laid, pavers must be installed against a perimeter border system (see instructions for loose-laid installation).

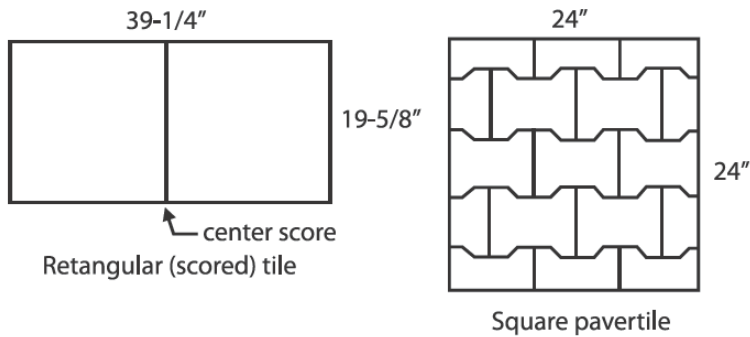

A. Indoor Installation

1. The material and adhesive must be acclimated at room temperature for a minimum of 48 hours before starting installation.
2. Lay out molded pavers/tiles before adhering to minimize cutting and waste.
3. Always begin installation with chalk lines that are perfectly square in the room. It is best to begin laying tiles away from the walls.
4. After all above procedures are performed, begin application of Ecore's E-Grip III, recommended one component polyurethane adhesive. Apply E-Grip III to the substrate using a 1/8" square notched trowel.
5. Apply E-Grip III evenly at a rate of approximately 60 square feet/gallon over smooth concrete. Various substrates may affect this coverage rate. Do not allow E-Grip III to cure on your hands or the flooring. Wipe off excess adhesive with a rag dampened with mineral spirits! Cured adhesive is very difficult to remove from hands.
NOTE: Use mineral spirits sparingly. Saturating the rubber with mineral spirits may cause the adhesive to be pushed too deeply into the pores of the rubber.
6. Place the first tile into the wet adhesive, making sure that the edges are precisely placed along chalk lines and where they intersect. Press firmly on the flooring to remove any curls or entrapped air.

INSTALLATION

B. Laying Tiles Indoors

1. Pavers: Interlock and shift whole pavers from left to right along chalk line #1 up to the wall on the opposite side of chalk line #2. The last paver will likely have to be cut to fit against the wall. (See diagram 7.)

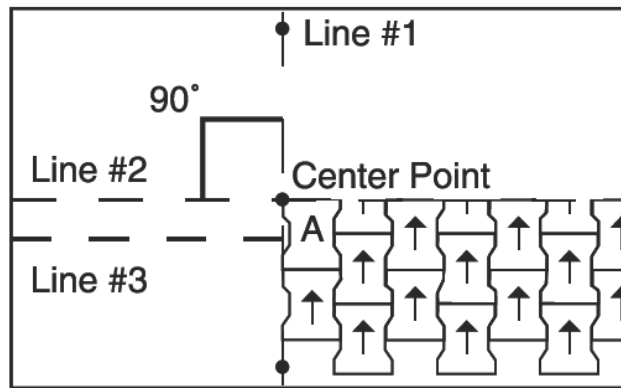

diagram 7

2. Tiles & Paver tiles: Place the first tile, A, into the wet adhesive, making sure that the edges are precisely placed along the chalk lines and where they intersect. Press firmly on the tiles to remove any curls or entrapped air. See diagram 5a or 5b.
3. Continue this process with each row until you reach the wall across from chalk line #1.
4. Go back and fill in gaps between the two original chalk lines and the wall on those two sides.
5. Immediately roll the floor with a 100 pound roller to ensure proper transfer of adhesive. Overlap each pass of the roller by 50% of the previous pass to ensure that the floor is properly rolled. Roll the width first then the length. Re-roll again after 30-45 minutes.
6. Keep foot traffic off the floor for a minimum of 24 hours. Foot traffic and rolling loads can cause permanent indentations in the uncured adhesive and cause tiles to shift.
7. Allow the adhesive to cure for a minimum of 24 hours before applying any sealer to the floor.

INSTALLATION

C. Outdoor Installation

1. Glue down installation on concrete, asphalt, and crushed stone. Base materials for ECOpave are fully cured concrete or asphalt. Both are ideal for load bearing areas with heavy traffic or moving vehicles.
2. Make sure to allow for a 1.5% slope or fall for moisture movement to drainage pit.
3. Bituminous concrete mixture requirements for asphalt top layer specifications are outlined below:

<u>Sieve Size</u>	<u>Opening</u>	<u>Millimeters</u>	<u>% Passing</u>
3/8"	.375	9.53	100
#4	.187	4.75	80
#8	.0937	2.36	54
#16	.0469	1.18	32
#30	.0234	0.60	18
#50	.0117	0.300	12
#100	.0059	0.150	9
#200	.0029	0.075	6

Note: A filter fabric is necessary for crushed stone bases. Tiles are adhered to the filter fabric. Over time, with this type of installation, edges may lift slightly, as the fabric is not adhered to the substrate. This type of installation is not recommended for vehicular traffic.

4. Lay out molded pavers/tiles before adhering to minimize cutting and waste.
5. Always begin installation with chalk lines that are perfectly square. It is best to begin laying product away from the walls.
6. After all above procedures are performed, begin application of Ecore's E-Grip III, recommended one component polyurethane adhesive. Apply E-Grip III to the substrate using a 1/8" square notched trowel.
7. Apply E-Grip III evenly at a rate of 60 square feet per gallon over smooth concrete. Various substrates may affect this coverage rate. Do not allow E-Grip III to cure on your hands or the flooring. Wipe off excess adhesive with a rag dampened with mineral spirits! Cured adhesive is very difficult to remove from hands.
NOTE: Use mineral spirits sparingly. Saturating the rubber with mineral spirits may cause the adhesive to be pushed too deeply into the pores of the rubber.
8. Place the molded pavers/tiles into the wet adhesive, making sure that the edges are precisely placed along chalk lines where they intersect. Press firmly on the flooring to remove any curls or entrapped air.

INSTALLATION

D. Laying Tiles - Outdoors

1. Pavers: Interlock and shift whole pavers from left to right along chalk line #1 up to the perimeter border on the opposite side of chalk line #2. The last paver will likely have to be cut to fit against the perimeter border. (See diagram 7.)
2. Tiles & Paver Tiles: Place the first tile, A, into the wet adhesive, making sure that the edges are precisely placed along the chalk lines and where they intersect. Press firmly on the tiles to remove any curls or entrapped air. (See diagrams 5a and 5b.)
3. Continue this process with each row until you reach the perimeter border across from chalk line #1.
4. Go back and fill in gaps between the two original chalk lines and the wall on those two sides.
5. Roll a 100 pound roller over the floor within 30 minutes to ensure proper transfer of adhesive. Overlap each pass of the roller by 50% of the previous pass to ensure the floor is properly rolled. Re-roll again after 30-45 minutes.
6. Keep foot traffic off the floor for a minimum of 24 hours. Foot traffic and rolling loads can cause permanent indentations in the uncured adhesive and cause tiles to shift.

E. Loose-Laid Installation: (Full Pavers Only)

1. Base Requirements
 - a. Base must contain sand/crushed stone with perimeter border system.
 - b. Pavers must be installed butting up against perimeter border system.
2. Crushed Stone Specifications
 - a. The 95% standard proctor compaction (as per ASTM D1557) is critical.
 - b. Stone for the base must be crushed, so it compacts to the above standard and should be a homogeneous mix of these sizes:
 - c.

<u>Sieve Size</u>	<u>% Passing by Weight</u>
1"	90-100
5/8"	50-80
1/4"	30-50
#4	15-35
#8	10-30
#30	3-5
#200	0-3
 - d. Minimum depth of crushed stone base should be 4".
 - e. Base can be flat or sloped 2%.
3. Procedure
 - a. Excavate soil approximately 12".
 - b. Replace soil with approximately 9" of compacted crushed stone and approximately 1" of damp leveling sand.
 - c. Install perimeter border system.
 - d. Lay pavers in desired pattern.

INSTALLATION

VIII. ECOCOMFORT

A. Installation Under ECOsurfaces

Please contact Ecore's Technical Department for details pertaining to this type of installation: 877-258-0843.

B. Installation Under Carpet

1. Complete Glue Down

- a. Install ECOcomfort on sub-base following sheet installation instructions.
- b. Adhere carpet to ECOcomfort using carpet manufacturer's recommended adhesive or tape.

2. Installation With (Wall-To-Wall) Tack Strips

- a. Install tack strips.
- b. Install ECOcomfort up to strips.
- c. Install carpeting over ECOcomfort following carpet manufacturer's recommended wall-to-wall installation instructions.

IMPORTANT INFORMATION FOR THE SPECIFIER:

Ecore recommends our environmentally friendly, E-Cleaner, E-Strip, and E-Finish Maintenance Products and Procedures for ECOsurfaces.

Proper protection and maintenance of ECOsurfaces post-installation should be specified by the architect/designer. ECOsurfaces should not be subject to construction debris and potential damage caused from heavy duty construction activities. The specifier should determine and assign the specific type of cleaning and products, dependent upon the type of material being installed. ECOsurfaces 3.2mm rolls feature factory applied ECOguard. Please check with Ecore Commercial Flooring for availability of products with ECOguard and current thicknesses. Please note that tiles do NOT have factory applied ECOguard finish.

MAINTENANCE

FLOOR PROTECTION, CLEANING AND MAINTENANCE

It is the responsibility of the specifier to provide the following.

Specification details to protect the floor post-installation and until job construction is complete, such as covering the entire floor with paper or other floor covering. This includes plastic, plywood, or masonite, until construction is complete.

The specifier should determine and assign the responsibility for the initial cleaning and finishing of ECOsurfaces. This responsibility should be specifically assigned to the flooring contractor, general contractor, maintenance contractor, or owner. All ECOsurfaces published procedures shall be followed.

It is the General Contractors responsibility to provide the following.

A building or installation area that is fully enclosed from the elements. The roof, windows, and doors shall be finished.

Temperature shall be climate controlled with a minimum uniform temperature of 65° F for 48 hours prior to, during, and after the ECOsurfaces flooring installation, so the flooring contractor can acclimate the flooring materials.

Areas of the flooring that are subject to direct sunlight through doors or windows shall have the doors or windows covered for such time until the installation of the ECOsurfaces material is complete.

Protect ECOsurfaces from damage and construction debris by using an appropriate floor covering. All sections shall be fully covered until such time that the recommended initial cleaning may be performed.

MAINTENANCE

UNCOATED CLEANING INSTRUCTIONS

Steps	Green Products	Dilute	Diluted Coverage	Pads & Brushes
Initial Cleaning	Ecore's E-Cleaner	10 oz./gal. water	2,000 sq. ft./gal.	Soft nylon brush or approved pad
Finishing	Ecore's E-Finish	None	1,500 sq. ft./gal.	Soft nylon brush or microfiber mop
Daily Cleaning	Ecore's E-Cleaner	2-4 oz./gal. water	6,000 sq. ft./gal.	Soft nylon brush or microfiber mop
Heavy Soil and Restorative Cleaning "Uncoated" Surfaces	Ecore's E-Strip	16 oz./gal. water	1,200 sq. ft./gal.	Brown pad or black pad

NOTE: For factory coated ECOsurfaces, please refer to instructions on page 20 of this manual.

I. Ecore CLEANING AND FINISHING PROGRAM

A. Initial Cleaning

1. Remove all surface soil, debris, sand, and grit by sweeping, dust mopping, or vacuuming.
2. Scrub floor with Ecore's recommended E-Cleaner, using buffer or auto scrubber with an approved* pad or soft nylon brush over uncoated ECOsurfaces.
3. Pick up solution with a wet vacuum, rinse with clean water, and allow to dry thoroughly (6-8 hours).

***Please call Ecore Commercial Flooring's Technical Department at 877-258-0843 for clarification on approved pads.**

B. Initial Floor Finish Application

1. Finish options:
 - a. Ecore's E-Finish for a low satin finish. Apply 2-3 thin coats of finish. Work finish into flooring with a soft nylon brush or microfiber mop and let it thoroughly dry between coats.
2. Provide sufficient cure time of the final coat before allowing foot traffic (at least 2 hours).

C. Daily/Regular Cleaning

1. Sweep, dust mop, or vacuum floor to remove surface soil, debris, sand, and grit.
2. Damp mop with a microfiber mop or auto-scrub with a soft nylon brush or microfiber mop using Ecore's approved E-Cleaner low foam cleaner.

Note: FLOORS TREATED WITH E-Finish - When cleaning floors finished with E-Finish, use only a microfiber mop and nylon brush. Pads will remove finish on floors treated with E-Finish.

MAINTENANCE

D. Restorative Maintenance

Stripping the finish is not needed until there is a noticeable accumulation of dirt and contaminants embedded in the finish. Normally this accumulation occurs in hard-to-reach and high traffic areas. Following a good maintenance program, and applying thin coats of finish when the look calls for it, and only where it is needed, will result in little finish build-up, increasing the time between stripping.

1. Sweep or vacuum to remove loose soil.
2. Heavy scrub using a rotary scrubber or automatic scrubber with an approved pad and stripper solution Ecore's E-Strip.
3. Pick up solution with wet vac.
4. Rinse with clean water.
5. Allow floor to thoroughly dry.
6. Apply floor finish following initial finish application instructions.

E. Heavy Soil

1. Hard-to-clean and greasy areas may require a higher concentration of Ecore's E-Cleaner and may require a restorative maintenance.

IMPORTANT MAINTENANCE TIPS

- Refer to ECOguard Maintenance Section for Factory Coated ECOsurfaces.
- Use high CFM vacuum.
- Wait for floor to dry thoroughly before applying floor finishes, usually 24 hours.
- Apply only thin coats of floor finishes with finish mop. Buff finish into the floor with a soft nylon brush.
- For stripping floors, use E-Strip and a black or brown pad. Rinse thoroughly with clean water.
- For gum, use any generic gum remover. However, any solvent-based product should be rinsed well with water to avoid damaging the floor. Gum remover will also remove finish.
- For high traffic areas, top scrub and recoat floor as needed.
- Avoid flooding the floor.

MAINTENANCE

CLEANING AND MAINTENANCE PROGRAM FOR ECOPAVE MOLDED PRODUCTS

(Interlocking Pavers, Rectangular Tiles, and Square Embossed Pavertiles)

- A. Outdoor Cleaning & Maintenance Procedures
 - 1. Daily cleaning: Sweep debris away or hose off dirt.
 - 2. Periodic cleaning (as needed): Pressure wash with no more than 1,200 psi maximum.
- B. Indoor Cleaning & Maintenance Procedures

NOTE: This product is not intended for residential indoor use, and should only be used indoors where a suitable drainage system is in place.

- 1. Daily cleaning: Vacuum floor or sweep floor to remove loose debris.
- 2. Periodic cleaning
 - a. Vacuum floor or sweep floor to remove loose debris.
 - b. Wet scrub floor with E-Cleaner, using an auto-scrubber with nylon brush.
 - c. Wet vacuum remaining soiled solution, rinse, and allow to dry thoroughly (6-8 hours).

MAINTENANCE**ECOguard Clear Coat Sealer Instructions****Description**

ECOguard is a water based, clear polyurethane maintenance coat. ECOguard is formulated for interior applications and offers excellent environmental resistance to abrasion and impact. It also offers an attractive matte finish.

Tools / Materials Required

Safety glasses
Latex or rubber gloves
21" paint tray or rectangular mop bucket for sealer
Applicator trim pads
Automatic buffer
Utility knife
Trash bags
18" stir sticks
Drill
Rags
Microfiber mop
Microfiber mop cover
Paint mixer paddle

MAINTENANCE

I. SURFACE PREPARATION

- A. An improperly prepared surface can act as a bond breaker and result in a project failure. It is important to remove all dirt, grease, wax, oil, paint, or other contaminants before applying the ECOguard. ECOguard can be applied over the existing factory applied finish after all construction debris and soil have been removed from the surface.

II. PRECAUTIONARY MEASURES

- A. Suggested to allow ECOguard to cure for 48 hours before cleaning.
- B. Suggested to allow ECOguard to cure for 48 hours before rolling chairs and dollies.
- C. Suggested to allow ECOguard to cure for 24 hours before introducing foot traffic.
- D. If traffic and/or rolling loads need to be introduced earlier than listed above, the surface should be protected with an appropriate plywood or Luan.
- E. Remove ECOguard spills and drips immediately from other surfaces before dry.
- F. Suggested not to re-use microfiber pads after applying ECOguard.
- G. Seal floor in one step rather than in sections for best results.
- H. If sealer dries on microfiber pad, replace with new microfiber pad for best results.
- I. Sealer will obtain full strength in 5-7 days. Care should be taken during the first 5-7 days to prevent damage to the coating. Extra coats will extend the curing cycle.
- J. Do not use string mops or other unapproved applicators to apply ECOguard. The use of unapproved mops may result in a poor application of the sealer and complete removal may be required.
- K. Work from one side of the room to the other using a scrubbing motion with microfiber mop keeping a wet edge.

III. APPLICATION METHODS

- A. Application Of ECOguard Over Uncoated ECOSurfaces
 1. **IMPORTANT: Stir the ECOguard thoroughly before application to ensure consistent sheen.** Stir sealer for 3-5 minutes or until all sediment at bottom of pail is mixed.
 2. Safety glasses should be worn when mixing, pouring, or applying ECOguard.
 3. Apply first coating of ECOguard to the rubber surface using Ecore's recommended microfiber mop. An applicator trim pad may be used for areas around the perimeter.
 4. An additional one to two coats are recommended and an ample amount of time is required between coats. Allow each coat to dry thoroughly to touch before applying the next coat, about 2 - 4 hours.
 5. Over unfinished rubber, the coverage rate is approximately 400-500 sq ft per gallon. Second and third coat coverage is approximately 600-800 square feet per gallon.
 6. Apply ECOguard when surface temperature is 65 degrees Fahrenheit or higher and maintained for 72 hours before and after installation.
 7. Wear rubber or latex gloves when applying ECOguard. Sealer will not harm the skin but is difficult to remove once it dries. Wash hands immediately after contact with ECOguard with soap and water.
 8. Allow ECOguard to cure for 48 hours before cleaning the surface.

MAINTENANCE

- B. Application Over Existing ECOguard Factory Applied Sealer
1. Factory coated product should not require additional field coats. Should an additional coat be requested, one should suffice.
 2. **IMPORTANT: Stir the ECOguard thoroughly before application to ensure consistent sheen.** Stir sealer for 3-5 minutes or until all sediment at bottom of pail is mixed.
 3. Safety glasses should be worn when mixing, pouring, or applying ECOguard.
 4. Wear rubber or latex gloves when applying ECOguard. Sealer will not harm the skin, but is difficult to remove once it dries. Wash hands immediately after contact with ECOguard with soap and water.
 5. Apply ECOguard when surface temperature is 65 degrees Fahrenheit or higher and maintained for 72 hours before and after installation.
 6. Apply one coating of ECOguard to the rubber surface using Ecore's recommended microfiber mop. An applicator trim pad may be used for areas around the perimeter.
 7. Additional coats are acceptable and an ample amount of time is required between coats. Allow each coat to dry thoroughly before applying the next coat, about 2-4 hours.
 8. Coverage rate is approximately 600-800 square feet per gallon over previously coated surfaces.
 9. Allow ECOguard to cure for 48 hours before cleaning the surface.
- C. Surface Preparation and Re-Application of ECOguard Sealer
1. An improperly prepared surface can act as a bond breaker and result in a project failure. It is important to remove all dirt, grease, wax, oil, paint, or other contaminants before re-applying ECOguard. ECOguard can be applied over the existing factory applied finish after all construction debris and soil have been removed from the surface.
 2. It is recommended to clean the surface thoroughly with a buffer or auto scrubber using a 3M red or aqua pad. Keep in mind that these pads will slightly abrade the finish and continued use will remove the sealer. Cleaning with these pads will slightly abrade the finish, creating an acceptable surface to apply the new finish coat.
 3. **NOTE:** Manufacturers make different pads of different texture in like colors. It is recommended to contact Ecore Commercial Floorings Technical Service Department for guidance in pad selection.
 4. **Stir the ECOguard thoroughly before application to ensure consistent sheen.**
 5. Apply one coating of ECOguard to the rubber surface using Ecore's recommended microfiber mop. An applicator trim pad or 4" roller may be used for areas around the perimeter.
 6. Additional coats are acceptable and an ample amount of time is required between coats. Allow each coat to dry thoroughly before applying the next coat, about 2-4 hours.
 7. Coverage rate is approximately 600-800 square feet per gallon over previously coated surfaces.
 8. Apply ECOguard when surface temperature is 65 degrees Fahrenheit or higher and maintained for 72 hours before and after installation.
 9. Safety glasses should be worn when mixing, pouring or applying ECOguard.
 10. Wear rubber or latex gloves when applying ECOguard. Sealer will not harm the skin but is difficult to remove once it dries. Wash hands with soap and water after contact.
 11. Allow ECOguard to cure for 48 hours before cleaning the surface.

MAINTENANCE

- D. Removal / Stripping ECOguard Sealer
1. ECOguard is difficult to completely remove from the surface of the rubber and may take several attempts. ECOguard is removed by abrasion using an approved stripping pad. Anything used to chemically remove the sealer will jeopardize the integrity of the rubber.
 2. To remove, use E-Strip 42 ounce per gallon water and a buffer fitted with a black or brown stripping pad. Manufacturers make different pads of different texture in like colors. **It is recommended to contact Ecore Commercial Floorings Technical Service Department for guidance in pad selection: 877-258-0843.**
 3. Apply a liberal amount of diluted stripper to the surface of the rubber and work buffer from one side to the other until sealer is removed. Successfully removing the sealer will be dependent on undulations in the substrate and may take several passes with the buffer or auto scrubber.
 4. **CAUTION – A “standard” black pad** should be the most aggressive pad used. **The use of a high performance black pad such as 3M’s 7300 series is NOT RECOMMENDED and will act as a sander and will damage the surface of the rubber.** Ecore assumes no liability in the event of damage to the rubber in the removal process. ECOguard is considered a permanent sealer and not intended to be stripped from the rubber as a standard procedure. This procedure is for restorative maintenance purposes only. To re-apply ECOguard please follow step 1.

MAINTENANCE

ECOsurfaces Coated with ECOguard

Steps	Green Products	Dilute	Tools
Initial Cleaning	Ecore's E-Cleaner	10 oz. / Gal Water	Soft Nylon Brush or Microfiber Mop
Daily/Weekly Cleaning	Ecore's E-Cleaner	2-4 oz. / Gal Water	Soft Nylon Brush or Microfiber Mop
Heavy Soil	Ecore's E-Cleaner	10 oz. / Gal Water	Soft Nylon Brush or approved pad

Please contact Ecore Commercial Floorings Technical department for assistance on cleaning and pad selection at 877-258-0843.

A. Initial Cleaning

NOTE: Sealer should have 48 hours minimum to cure before introducing moisture.

1. Remove all surface soil, debris, sand, and grit by sweeping or vacuuming.
2. Scrub floor with Ecore's recommended E-Cleaner, using a buffer or auto scrubber with a soft nylon brush. We recommend a 175 RPM buffer or auto scrubber. If soil is minimal, a microfiber mop may be used.
3. Pick up remaining residue with a wet vac and damp mop floor. Allow floor to dry.

B. Daily/Weekly Cleaning

1. Remove all surface soil, debris, sand, and grit by sweeping or vacuuming.
2. Damp mop or scrub floor using Ecore's recommended E-Cleaner or equivalent with a soft nylon brush or microfiber mop. For heavier scuff marks, a more aggressive pad may be used. **Please contact Ecore's Technical Department for guidelines on pad selection at 877-258-0843**
3. Clean remaining residue from floor with a wet vac and damp mop floor. Allow floor to dry thoroughly before introducing foot traffic.

C. Heavy Soil Cleaning

1. Remove all surface soil, debris, sand, and grit by sweeping or vacuuming.
2. Scrub floor using Ecore's recommended E-Cleaner with a soft nylon brush or more aggressive recommended pad. **Contact Ecore's Technical Department for aid in pad selection.** "Follow Dilution Schedule" above.
3. Pick up remaining residue with a wet vac and damp mop floor. Allow floor to dry.

Note: If area is too small for a buffer or auto scrubber, a nylon deck brush may be used to remove scuff marks or heavy soil. Brush should be approximately 22 gauge.

Approved Cleaning / Stripping Pads

Manufacturer	Cleaning	Stripping
3 M	White 4100, Beige 4200	Black 7200, Brown 7100, Blue 5300
Taski	White	Black, Purple
ECOLAB	White	Black

RECOMMENDED TOOLS AND MATERIALS



21" Paint Tray



Microfiber Mop



Microfiber Mop Cover



Rectangular Mop Bucket



Applicator Trim Pad



Applicator Trim Pad



Mixing Paddle



Safety Glasses



Safety Knife



Latex Gloves



Shop Towels



Rags

ECOGUARD QUESTIONS AND ANSWERS

What is ECOguard? ECOguard is a water-based polymeric coating made exclusively for Ecore to preserve the beauty of ECOSurfaces floors. It is factory applied to 3.2 mm ECOSurfaces sheet flooring products to protect the floor from dirt and construction debris, significantly reducing initial cleaning and maintenance costs.

Is ECOguard environmentally friendly? Factory applied ECOguard has low VOCs and emits no Proposition 65 chemicals. ECOguard also meets the California Section 01350 protocol for use in schools and offices. In addition, no respirator masks are required during application of the ECOguard.

What is ECOguard's life expectancy? ECOguard is a long lasting, durable finish that will provide many years of service with normal use and foot traffic. Products finished with ECOguard will carry the same 5 year warranty currently offered on ECOSurfaces products. An extended wear warranty will not be offered. We estimate the initial factory finish, plus the additional field-applied coat will last 1-5 years, depending upon use. As a general rule ECOguard should last 5 years in a residential environment, 2 years in a commercial environment, and 1 year in an industrial environment.

Does ECOguard impact how ECOSurfaces products are installed? No. The seaming methods are the same for ECOSurfaces 3.2mm - 6mm factory finished goods.

How is it maintained once installed? Initial cleaning can be performed with a neutral cleaner in conjunction with a buffer fitted with a soft nylon brush. Aggressive scrub pads will damage the surface sheen, and therefore are not recommended. Daily cleaning is best carried out with a neutral cleaner and a microfiber mop. Complete instructions on cleaning and maintenance are available for download at www.ecorecommercialflooring.com.

How do you remove adhesive residue without damaging the ECOguard finish? A rag dampened with mineral spirits is the only acceptable solvent to use for removing adhesive residue. Other solvents such as acetone, xylene, denatured alcohol, and scrub pads will damage ECOguard's finish.

When is ECOguard available? ECOSurfaces products factory sealed with ECOguard are available immediately.

Will ECOguard be available on all thicknesses of ECOSurfaces? We can factory finish 3.2mm, 6mm and 8mm sheet products. For other Ecore products the ECOguard hand applied sealer may be used.

Is ECOguard UV stable? ECOguard does not change under long term UV exposure. Long term lab and exterior UV testing has shown positive results with minimal color change or discoloration.

Is ECOguard available in semi-gloss or gloss finishes? We only offer the matte finish for ECOguard from the factory, as it provides the most natural look of ECOSurfaces.

Can ECOguard be removed or stripped from the floor? ECOguard is considered a permanent finish and will be difficult to remove from the floor. Detailed instructions, including finishing, cleaning, stripping, and re-coating are available for download at www.ecorecommercialflooring.com.

Can ECOguard be re-used once the pail has been opened? Yes, simply stir the bucket thoroughly and re-use as needed. However, once opened, the material should be used within two weeks.

WARRANTY

All Ecore rubber flooring is guaranteed to be free from manufacturing defects on both material and workmanship. If such a defect is discovered, the customer must notify Ecore either through the contracting installer, distributor, or directly. If found to be defective within five years under normal non-abusive conditions, the sole remedy against the seller will be the replacement or repair of the defective goods, or at the seller's option, credit may be issued not exceeding the selling price of the defective goods.

ECOsurfaces warranty shall not cover dissatisfaction due to improper installation, normal wear or quality of installation expected from the use or environment of installation, damage from improper maintenance or usage, or general misuse, including and without limitation: burns, cuts, tears, scratches, scuffs, damage from rolling loads, damage from cleaning products not recommended by Ecore, slight shade variations or shade variations due to exposure to direct sunlight, or differences in color between samples or photographs and actual flooring.

Excluded from Warranty – ECOsurfaces warranty does not apply to the following.

1. The exact matching of shade, color, or mottling.
2. Any express or implied promise made by any salesman or representative.
3. Tears, burns, cuts, or damage due to improper installation, improper use, or improper cleaning agents or maintenance methods.
4. Wear from chairs or other furniture without proper floor protectors will void the warranty. Care should be taken to protect the flooring from damage by using good quality protective feet for chairs, tables, and other furniture. Chair mats may be required under chairs with casters/wheels.
5. Labor costs for installation of original or replacement material.
6. Sale of "seconds," "off goods," or other irregular (non-first-quality) flooring materials. With respect to "seconds" or "off goods," such are sold "as is," and Ecore makes no warranties whatsoever, express or implied with respect thereto, including warranties of merchantability or fitness for a particular purpose.
7. Problems caused by moisture, hydrostatic pressure, or alkali in the sub-floor.
8. Problems caused by uses, maintenance, and installation that are contrary to Ecore Commercial Flooring specifications, recommendations or instructions.
9. Material installed with obvious defects.
10. Damage to flooring products from high heels or spike heels.
11. Damage to flooring products from rubber mats, rubber backed mats, or car tires.
12. Installation of ECOsurfaces products with adhesives other than those recommended by Ecore Commercial Flooring.
13. Fading and/or discoloration resulting from heavy sunlight penetration and ultraviolet ray exposure from direct or glass-filtered sunlight.
14. Material that is not installed and maintained as recommended by Ecore Commercial Flooring.
15. Damage to flooring products from pallet jack and tow-motor traffic.
16. Environments where the product will be exposed to animal fats, vegetable oils, grease, or petroleum based materials. (i.e.: commercial kitchens or auto repair facilities)
17. Premature wear and deterioration from spikes and skate blade exposure.
18. Differences in color between products and photography.
19. Embossing/density deviations between product and samples, photography.

These warranties are in lieu of any other warranty expressed or implied. Ecore Commercial Flooring shall not be liable for any incidental or consequential damages which may result from a defect. Some states do not allow the exclusion or limitation of incidental or consequential damages, so the above limitation or exclusion may not apply to you. These warranties give you specific rights, and you may also have rights which may vary from state to state. To know what your legal rights are in your state, consult your local or state Consumer Affairs Office or your State Attorney General.

For complete and latest warranty information for products within the ECOsurfaces collection please visit www.ecorecommercialflooring.com.



800-258-08431 – www.ecorecommercialflooring.com

Manufactured in the U.S.A. by:

The Ecore logo, consisting of the word "ecore" in a bold, lowercase, blue, sans-serif font.

715 Fountain Ave – Lancaster, PA 17601

©2015 All designs and colors are copyrighted by Ecore. ECOSurfaces is a registered trademark of Ecore