



## **ECOnights Rolls and Tiles**

# **TECHNICAL MANUAL**

**Installation • Maintenance • Warranty**

**Manufactured in the U.S.A. by:**

**ecore**

Revised on 02/22/2018  
Supersedes all previous versions.  
Check website for updates.

## TABLE OF CONTENTS

### INSTALLATION

Job Site Conditions	2
Subfloors	2
Subfloor Preparation	2-4
Storage & Handling	4-5
Roll Installation	4-8
Tile Installation	8-10
ECOcomfort Installation	11

### MAINTENANCE

Floor protection	12
Assignment of Cleaning	12
Cleaning Chart Uncoated	13
Cleaning Procedures Uncoated	13

### WARRANTY

WARRANTY	14
----------	----

## INSTALLATION

### I. JOB SITE CONDITIONS

- A. Installation should not begin until after all other trades are finished in the area. If the job requires other trades to work in the area after the installation of the floor, the flooring should be protected with an appropriate cover.
- B. Areas to receive flooring should be weather tight and maintained at a minimum uniform temperature of 65° F (18° C) for 48 hours prior to, during, and after installation.

### II. SUBFLOORS

ECOsurfaces and ECOcomfort rolls and tiles may be installed over concrete, approved Portland based self-leveling materials, and wood.

**Note:** Gypsum based patching and leveling compounds are not acceptable.

- A. Wood Subfloors: Wood subfloors should be double construction with a minimum thickness of 1". The floor must be rigid, free from movement, and have at least 18" of well-ventilated air space below.
- B. Underlayments: The preferred underlayment panel is APA underlayment grade plywood, minimum thickness of 1/4", with a fully sanded face.

**Note:** Particle board, chip board, Masonite, and lauan are not suitable underlayments.

- C. Concrete Floors: Concrete shall have a minimum compressive strength of 3000 psi. It must be fully cured and permanently dry.

### III. SUBFLOOR REQUIREMENTS AND PREPARATION

- A. Subfloor shall be dry, clean, smooth, level, and structurally sound. It should be free of dust, solvent, paint, wax, oil, grease, asphalt, sealers, curing and hardening compounds, alkaline salts, old adhesive residue, and other extraneous materials, according to ASTM F710.
- B. Subfloor should be smooth to prevent irregularities, roughness, or other defects from telegraphing through the new flooring. The surface should be flat to the equivalent of 3/16" (4.8 mm) in 10 feet (3.0 m).
- C. Mechanically remove all traces of old adhesives, paint, or other debris by scraping, sanding, or scarifying the substrate. Do not use solvents. All high spots shall be ground level and low spots filled with an approved cementitious based patching compound.
- D. All saw cuts (control joints), cracks, indentations, and other non-moving joints in the concrete must be filled with an approved cementitious based patching compound.
- E. Expansion joints in the concrete are designed to allow for expansion and contraction of the concrete. If a floor covering is installed over an expansion joint, it more than likely will fail in that area. Expansion joint covers designed for resilient floor coverings should be used.
- F. Always allow patching materials to dry thoroughly and install according to the manufacturer's instructions. Excessive moisture in patching material may cause bonding problems or a bubbling reaction with the E-Grip III™ adhesive.

## INSTALLATION

### HAZARDS:

**SILICA WARNING** - Concrete, floor patching compounds, toppings, and leveling compounds can contain free crystalline silica. Respirable crystalline silica (particles 1-10 micrometers) can be produced by cutting, sawing, grinding, or drilling. Respirable silica is classified by OSHA as an IA carcinogen and is known to cause silicosis and other respiratory diseases. Avoid actions that cause dust to become airborne. Use local or general ventilation, or protective equipment, to reduce exposure below applicable exposure limits.

**ASBESTOS WARNING** - Resilient flooring, backing, lining felt, paint, or asphaltic “cutback” adhesives can contain asbestos fibers. Avoid actions that cause dust to become airborne. Do not sand, dry sweep, dry scrape, drill, saw, beadblast, or mechanically chip or pulverize. Regulations may require that the material be tested to determine asbestos content. Consult the documents titled, “Recommended Work Practices for Removal of Existing Resilient Floor Coverings,” available from the Resilient Floor Covering Institute.

**LEAD WARNING** - Certain paints can contain lead. Exposure to excessive amounts of lead dust presents a health hazard. Refer to applicable federal, state, and local laws and the publication, “Lead Based Paint: Guidelines for Hazard Identification and Abatement in Public and Indian Housing,” available from the United States Department of Housing and Urban Development.

- G. Moisture must be measured using the RH Relative Humidity test method per ASTM F2170 standard. Moisture content should not exceed 85% RH. If the levels exceed the limitations, the installation should not proceed until the situation has been corrected.
- H. In the event that a moisture mitigation system is required, it must conform to the ASTM F3010 Standard Practice for Two-Component Resin Based Membrane Forming Moisture Mitigation Systems for use Under Resilient Floor Coverings.
- I. It is essential that pH tests be taken on all concrete floors. If the pH is greater than 9, it must be neutralized prior to beginning the installation.
- J. Adhesive bond tests should be conducted in several locations throughout the area. Glue down 3' x 3' test pieces of the flooring with the recommended adhesive and trowel. Allow to set for 72 hours before attempting to remove. A sufficient amount of force should be required to remove the flooring and, when removed, there should be adhesive residue on the subfloor and on the back of the test pieces.
- K. It is essential that pH tests be taken on all concrete floors. If the pH is greater than 9, it must be neutralized prior to beginning the installation.
- L. Adhesive bond tests should be conducted in several locations throughout the area. Glue down 3' x 3' pieces of the flooring with the recommended adhesive and trowel. Allow to set for 72 hours before attempting to remove. A sufficient amount of force should be required to remove the flooring, and there should be adhesive on the subfloor and the back of the

# INSTALLATION

**IV. Material Storage and Handling**

- A. Material should be delivered to the job site in its original unopened packaging with all labels intact.
- B. Roll material should always be stored lying down. Storing rubber on end will curl the edges, resulting in permanent memory of the material. Do not store rolls higher than 4 rolls or for more than 6 months.
- C. All edges with memory curl should be straight cut before installation. In some instances it may be necessary to weigh down the seam until adhesive develops a firm set.
- D. Inspect all material for visual defects prior to beginning the installation. No labor claim will be honored on material installed with visual defects. Verify the material delivered is the correct style, color, and amount. Any discrepancies must be reported immediately before beginning installation.
- E. The material and adhesive must be acclimated at room temperature for a minimum of 48 hours before starting installation.

**NOTE:** ECOsurfaces flooring is manufactured from recycled materials and slight variance in shade and color chip dispersion is normal. It is the installer’s responsibility to inspect all products to ensure the correct style, thickness, and color. Any moderate to severe discrepancies should be reported immediately before beginning installation.

- F. All ECOsurfaces rolls must be unrolled and installed in the same direction (directional arrows are stamped on bottom of the rolls). ECOsurfaces tiles must also be installed in the same direction (arrows on the bottom must be pointing in the same direction). Rolls are labeled with batch numbers and roll numbers. Do not mix batch numbers together and install all rolls in consecutive order. (See diagram 1.)

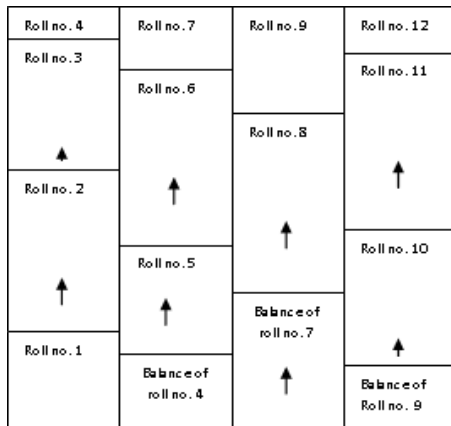

- G. Roll material is stretched slightly when it is rolled at the factory. At the job site, the installer should allow all rolls to relax for a minimum of two hours before gluing or cutting material.

## INSTALLATION

- V. INSTALLATION - SHEET 3.2mm and 6mm 51" wide rolls only. (48" wide rolls see Section VI.)**
- A. Cut the first sheet at the required length, including enough to run up the wall and overlap for seaming at each end.
  - B. Position the first sheet against the wall and square with the room.
  - C. Cut second sheet with proper extra length.
  - D. **Position second sheet with required overlap over the first roll at the seam.**  
**Each 51" roll must be overlapped by 5" with the cut made 2-1/2" in from the seam edge.**  
**Failure to comply with required overlap could result in shade variance between rolls.**
- IMPORTANT - Overlap amount is dependent upon the width of material provided.**  
**Please refer to seaming method diagrams for proper overlap amounts required.**
- E. Repeat for each consecutive sheet necessary to complete the area or those rolls that will be installed that day.
  - F. Allow the rough cuts to relax in position for a minimum of 2 hours before double cutting seams and applying the adhesive.
  - G. **SEAMING METHODS 3.2mm and 6mm only. (8mm and thicker skip to Section VII)**
    1. 1/4" (6mm) and thinner: Place a 4" wide scrap of material under the seam area. Using a straight edge and new razor blade, hold the knife straight up and down and cut through both pieces in one cut.

**NOTE: Each 51" roll must be overlapped by 5" with the cut made 2-1/2" in from seam edge.**

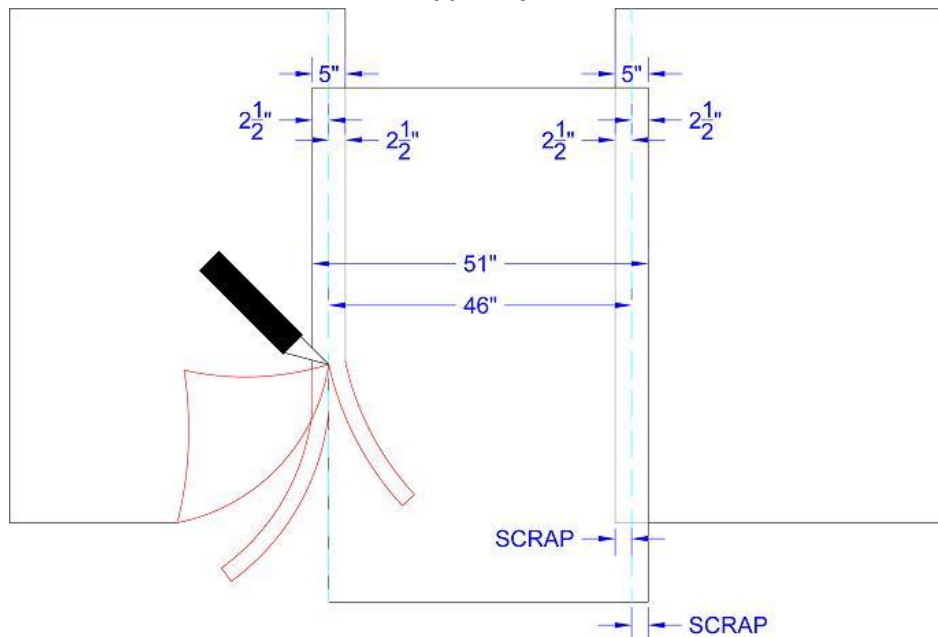

**51" Wide Rolls must be overlapped 5" with the cut made 2-1/2" in from seam edge**



## INSTALLATION

### VI. INSTALLATION - SHEET 3.2mm and 6mm 48" wide rolls only. (51" rolls see Section V.)

- A. Cut the first sheet at the required length, including enough to run up the wall and overlap for seaming at each end.
- B. Position the first sheet against the wall and square with the room.
- C. Cut second sheet with proper extra length.
- D. **Position second sheet with required overlap over the first roll at the seam.**  
**Each 48" roll must be overlapped by 2" with the cut made 1" in from the seam edge.**  
**Failure to comply with required overlap could result in shade variance between rolls.**

**IMPORTANT** - Overlap amount is dependent upon the width of material provided.  
**Please refer to seaming method diagrams for proper overlap amounts required.**

- E. Repeat for each consecutive sheet necessary to complete the area or those rolls that will be installed that day.
- F. Allow the rough cuts to relax in position for a minimum of 2 hours before double cutting seams and applying the adhesive.
- G. **SEAMING METHODS 3.2mm and 6mm only. (8mm and thicker skip to Section VII)**
  2. 1/4" (6mm) and thinner: Place a 4" wide scrap of material under the seam area. Using a straight edge and new razor blade, hold the knife straight up and down and cut through both pieces in one cut.

**NOTE: Each 48" roll must be overlapped by 2" with the cut made 1" in from the seam edge**

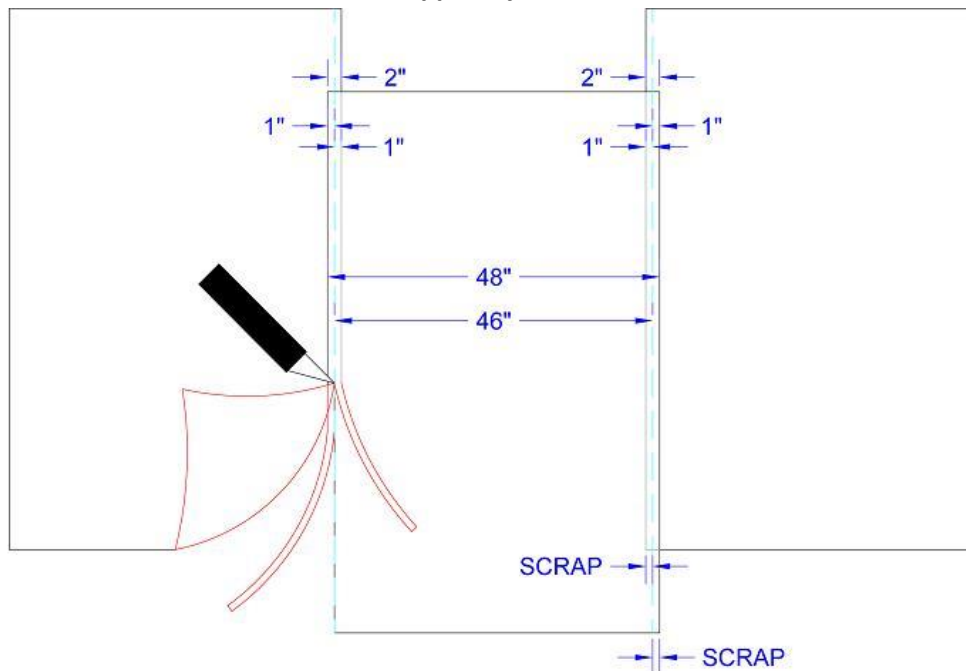

**48" Wide Rolls must be overlapped 2" with the cut made 1" in from the seam edge**

## INSTALLATION

### VII. INSTALLATION - SHEET 8mm and Thicker Material.

- A. Make the assumption that the walls you are butting against are not straight or square. Using a chalk line, make a starting point for an edge of the flooring to follow. The chalk line should be set where the first seam will be located.
- B. Remove the ECONights from the shrink wrap and unroll it onto the floor. Lay the rubber on the floor in a way that will use your cuts efficiently. Cut all rolls at the required length, including enough to run up the wall a few inches.
- C. If end seams are necessary, they should be staggered on the floor and overlapped approximately 3-6". End seams will be trimmed after acclimation period, using a square to ensure they fit tightly without gaps.
- D. Allow the rough cuts to relax in position for a minimum of two hours. 24 hours is preferred.
- E. After allowing the flooring to relax, you may begin the installation.
- F. Align the first edge to the chalk line.

**Note: it is very important the first seam is perfectly straight.**

- G. Position the second roll with no more than a 1/8" overlap over the first roll at the seam. After adhesive is applied to substrate, the material will be worked back to eliminate the overlap. This procedure will leave tight seams and eliminate any gaps.
- H. Care should be taken to not over compress the seam. Over compressed seams will cause peaking.

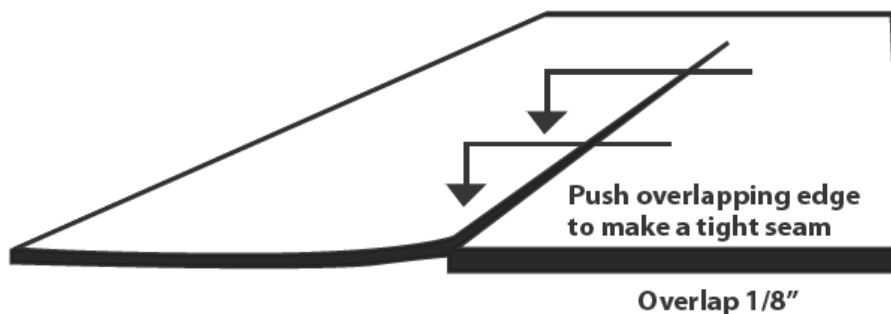

diagram 3

- I. It may be necessary to trim the edge of the second lineal drop, if the rolls do not extend the length or width of the room. Rolls laid end-to-end with a variance in roll width greater than 1/4" could result in peaked seams.
- J. Repeat for each consecutive sheet necessary to complete the area or those rolls that will be installed that day.



## INSTALLATION

### VIII. ADHESIVE APPLICATION

- A. After all above procedures are performed, begin application of Ecore's E-Grip III, making sure to use the proper recommended trowel size:

3.2mm – 1/16" x 1/32" x 5/64" U-Notched Trowel  
 6mm– 1/16" x 1/16" x 1/16" Square Notched trowel  
 8mm– 1/16" x 1/16" x 1/16" Square Notched Trowel

- B. Fold the first drop lengthwise (half the width of the roll).  
 C. Spread adhesive using the proper notched trowel. Take care not to spread more E-Grip III than can be covered by flooring and rolled within 30 minutes. The open time of the adhesive is 30 - 40 minutes at 70° F and 50% relative humidity.

**Note:** The open time of adhesive is affected by temperature and humidity. High temperatures and high humidity will cause the adhesive to set quickly. Low temperatures and low humidity will cause adhesive to cure at a slower rate. The installer should monitor on-site conditions and adjust open time accordingly.

- D. Carefully lay the material into the wet adhesive. DO NOT let the material drop, because this will cause air to be trapped beneath the flooring.  
 E. Immediately roll the floor with a 75 pound or 100 pound roller to ensure proper transfer of adhesive. Overlap each pass of the roller by 50% of the previous pass to ensure that the floor is properly rolled. Roll the width first, then the length. Re-roll again after 30-45 minutes.  
 F. Fold over second half of first roll and half of second sheet. Spread adhesive. At seam area spread adhesive at 90 degrees to seam to eliminate excessive adhesive oozing up at seam.  
 G. In some instances it may be necessary to weigh down the seam until the adhesive develops a firm set. Boxes of cove base or tile work well.  
 H. Continue the process for each consecutive drop. Always work at a pace so you are always folding material back into wet adhesive.

**NOTE:** Never leave adhesive ridges or puddles, they will telegraph through the material.

- I. Do not allow E-Grip III to cure on your hands or the flooring. Cured adhesive is very difficult to remove. We strongly suggest wearing gloves while using E-Grip III. Immediately wipe off excess adhesive with a rag slightly dampened with mineral spirits. Follow the mineral spirits with a rag dampened with water to remove the mineral spirits.

**NOTE:** Use mineral spirits sparingly. Saturating the rubber with mineral spirits may cause the adhesive to be pushed too deeply into the pores of the rubber.

- J. Hand roll all seams after the entire floor has been rolled. If some seams are gapping, it is possible to hold them together temporarily with blue painters tape. Tape should be removed after adhesive has developed a firm set (approximately 2-3 hours). Allowing tape to remain longer than 2-3 hours or using aggressive tapes may result in adhesive residue. Ecore will not be responsible for residue left behind from tape of any kind.

# INSTALLATION

- K. After you've rolled the floor, keep all foot traffic off the floor for a minimum of 24 hours. Foot traffic and rolling loads can cause permanent indentations or bubbles in the uncured adhesive.

## IX. INSTALLATION - TILES

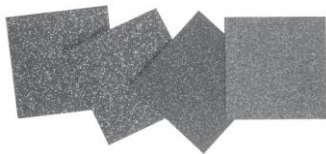

- A. Inspect tiles for visual defects, including shade variances prior to beginning the installation. No labor claim will be honored on material installed with visual defects. Any moderate to severe discrepancies should be reported immediately before beginning installation.
- B. ECOsurfaces tiles are manufactured from recycled materials and slight variance in shade and color chip dispersion is normal. It is the installer's responsibility to lay out tiles prior to installation and inspect them to ensure correct style, thickness, size, and color.
- C. Tiles manufactured from mats are intended for smaller installations. Larger quantities resulting in multiple dye lots may not be an exact match in shade or density. Every effort is made to ensure the best possible match; however, Ecore makes no warranty on the exact match between dye lots.
- D. All ECOsurfaces tiles must be installed from the same product group. Mixing multiple patterns may result in the installation to be thrown out of square. All tiles are marked on the bottom with arrows. Failure to install directionally will result in an out of square installation.
- E. Please contact Ecore Technical Services Department for clarification at 877-258-0843, before beginning the installation.
- F. Measure the width of the area to be covered.
- G. Mark the center of the area at two points, one at each end.
- H. Snap the chalk line, line #1, through these two points.
- I. Determine the center point of the chalk line.
- J. Using a Carpenter's square or another method, snap a second chalk line, line #2, perpendicular (at 90 degrees) to the first line. The lines should intersect at their centers.

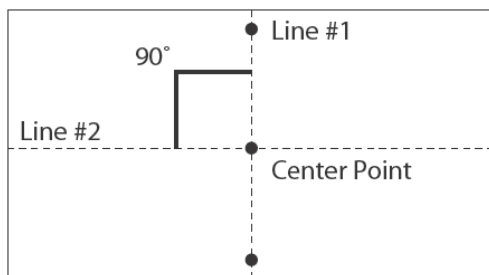

diagram 5a

- K. The area to be covered is now divided into quarters. Begin the installation at the center of the area, where the two lines intersect.

# INSTALLATION

**Note:** To lay tiles in an ashlar configuration, snap a third chalk line perpendicular to line #2 and parallel to line #1. The distance between line #1 and line #3 should be 1/2 the width of the tile (12 inches). (See diagram 6.)

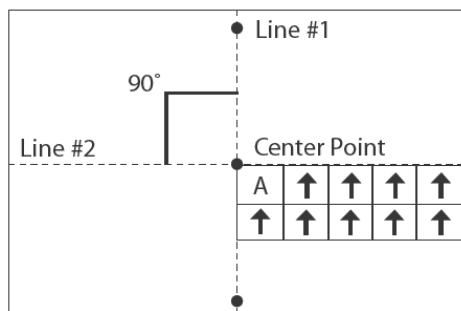

diagram 5b

- L. After all above procedures are performed, begin application of Ecore’s E-Grip III, making sure to use the proper recommended trowel size.

- 3.2mm – 1/16” x 1/32” x 5/64” U-Notched Trowel
- 6mm– 1/16” x 1/16” x 1/16” Square Notched trowel
- 8mm– 1/16” x 1/16” x 1/16” Square Notched Trowel

- M. Take care not to spread more adhesive than can be covered by flooring and rolled within 30 minutes.
- N. Place the first tile, A, into the wet adhesive, making sure that the edges are precisely placed along the chalk lines and where they intersect. Press firmly on the tiles to remove any curls or entrapped air. **Do not try to stretch or compress fit the tiles.** (See diagrams 5b and 6.)

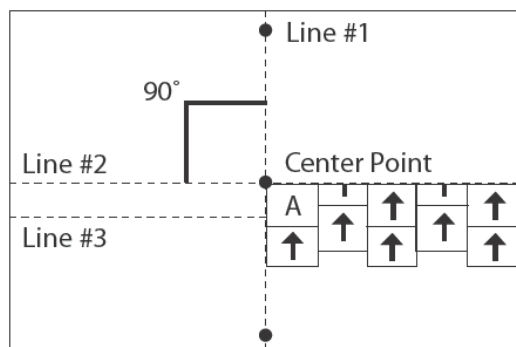

diagram 6

**Reminder: Arrows on bottom of tiles must point in the same direction.**

- O. Lay whole tiles from left to right along chalk line #1 up to the wall on the opposite side of chalk line #2. The last tile will likely have to be cut to fit against the wall.

## INSTALLATION

- P. Do not allow E-Grip III to cure on your hands or the flooring. Wipe off excess adhesive with a rag dampened with mineral spirits! Cured adhesive is very difficult to remove from hands.

**NOTE:** Use mineral spirits sparingly. Saturating the rubber with mineral spirits may cause the adhesive to be pushed too deeply into the pores of the rubber.

- Q. Continue this process with each row until you reach the wall across from chalk line #1.
- R. Go back and fill in gaps between the two original chalk lines and the wall on those two sides.
- O. If some seams are gapping, it is possible to hold them together temporarily with blue painters tape. Tape should be removed after adhesive has developed a firm set (approximately 2-3 hours). Allowing tape to remain longer than 2-3 hours or using aggressive tapes may result in adhesive residue. Ecore will not be responsible for residue left behind from tape of any kind.
- P. Roll a 75 pound or 100 pound roller over the floor within 45 minutes to ensure proper transfer of adhesive. Overlap each pass of the roller by 50% of the previous pass to ensure that the floor is properly rolled. Re-roll again after 30-45 minutes.
- Q. Keep foot traffic off the floor for a minimum of 24 hours. Foot traffic and rolling loads can cause permanent indentations in the uncured adhesive and cause tiles to shift.

### X. ECOCOMFORT

- A. Installation Under ECOsurfaces

Please contact Ecore's Technical Department for details pertaining to this type of installation: 877-258-0843.

- B. Installation Under Carpet

1. Complete Glue Down
  - a. Install ECOcomfort on sub-base following sheet installation instructions.
  - b. Adhere carpet to ECOcomfort using carpet manufacturer's recommended adhesive or tape.
2. Installation With (Wall-To-Wall) Tack Strips
  - a. Install tack strips.
  - b. Install ECOcomfort up to strips.
  - c. Install carpeting over ECOcomfort following carpet manufacturer's recommended wall-to-wall installation instructions.

## MAINTENANCE

### **IMPORTANT INFORMATION FOR THE SPECIFIER:**

Ecore recommends our environmentally friendly E-Cleaner and E-Strip Maintenance Products and Procedures for ECOsurfaces.

Proper protection and maintenance of ECOsurfaces post-installation should be specified by the architect/designer. ECOsurfaces should not be subject to construction debris and potential damage caused from heavy duty construction activities. The specifier should determine and assign the specific type of cleaning and products, dependent upon the type of material being installed.

### **FLOOR PROTECTION, CLEANING AND MAINTENANCE**

#### **It is the responsibility of the specifier to provide the following.**

Specification details to protect the floor post-installation and until job construction is complete, such as covering the entire floor with paper or other floor covering. This includes plastic, plywood, or masonite, until construction is complete.

The specifier should determine and assign the responsibility for the initial cleaning and finishing of ECOsurfaces. This responsibility should be specifically assigned to the flooring contractor, general contractor, maintenance contractor, or owner. All ECOsurfaces published procedures shall be followed.

#### **It is the General Contractors responsibility to provide the following.**

A building or installation area that is fully enclosed from the elements. The roof, windows, and doors shall be finished.

Temperature shall be climate controlled with a minimum uniform temperature of 65° F for 48 hours prior to, during, and after the ECOsurfaces flooring installation, so the flooring contractor can acclimate the flooring materials.

Areas of the flooring that are subject to direct sunlight through doors or windows shall have the doors or windows covered for such time until the installation of the ECOsurfaces material is complete.

Protect ECOsurfaces from damage and construction debris by using an appropriate floor covering. All sections shall be fully covered until such time that the recommended initial cleaning may be performed.

## MAINTENANCE

### UNCOATED CLEANING INSTRUCTIONS

Steps	Green Products	Dilute	Diluted Coverage	Pads & Brushes
Initial Cleaning	Ecore's E-Cleaner	10 oz./gal. water	2,000 sq. ft./gal.	Soft nylon brush or approved pad
Daily Cleaning	Ecore's E-Cleaner	2-4 oz./gal. water	6,000 sq. ft./gal.	Soft nylon brush or microfiber mop
Heavy Soil and Restorative Cleaning "Uncoated" Surfaces	Ecore's E-Strip	16 oz./gal. water	1,200 sq. ft./gal.	Brown pad or black pad

#### I. Ecore Cleaning Program

##### A. Initial Cleaning

1. Remove all surface soil, debris, sand, and grit by sweeping, dust mopping, or vacuuming.
2. Scrub floor with Ecore's recommended E-Cleaner, using buffer or auto scrubber with an approved\* pad or soft nylon brush over uncoated ECOsurfaces.
3. Pick up solution with a wet vacuum, rinse with clean water, and allow to dry thoroughly (6-8 hours).

**\*Please call Ecore's Technical Department at 866-795-2732 for clarification on approved pads.**

##### B. Daily/Regular Cleaning

1. Sweep, dust mop, or vacuum floor to remove surface soil, debris, sand, and grit.
2. Damp mop with a microfiber mop or auto-scrub with a soft nylon brush or microfiber mop using Ecore's approved E-Cleaner low foam cleaner.

##### C. Restorative Maintenance

Restorative maintenance is not needed until there is a noticeable accumulation of dirt and contaminant build up. Normally this accumulation occurs in hard-to-reach and high traffic areas. A good maintenance program will minimize the frequency of restorative cleanings.

1. Sweep or vacuum to remove loose soil.
2. Heavy scrub using a rotary scrubber or automatic scrubber with an approved pad and stripper solution Ecore's E-Strip.
3. Pick up solution with wet vac.
4. Rinse with clean water.
5. Allow floor to thoroughly dry.
6. Apply floor finish following initial finish application instructions.

##### D. Heavy Soil

1. Hard-to-clean and greasy areas may require a higher concentration of Ecore's E-Cleaner and may require a restorative maintenance.

## WARRANTY

All Ecore rubber flooring is guaranteed to be free from manufacturing defects on both material and workmanship. If such a defect is discovered, the customer must notify Ecore either through the contracting installer, distributor, or directly. If found to be defective within five years under normal non-abusive conditions, the sole remedy against the seller will be the replacement or repair of the defective goods, or at the seller's option, credit may be issued not exceeding the selling price of the defective goods.

ECOsurfaces warranty shall not cover dissatisfaction due to improper installation, normal wear or quality of installation expected from the use or environment of installation, damage from improper maintenance or usage, or general misuse, including and without limitation: burns, cuts, tears, scratches, scuffs, damage from rolling loads, damage from cleaning products not recommended by Ecore, slight shade variations or shade variations due to exposure to direct sunlight, or differences in color between samples or photographs and actual flooring.

**Excluded from Warranty** – ECOsurfaces warranty does not apply to the following.

1. The exact matching of shade, color, or mottling.
2. Any express or implied promise made by any salesman or representative.
3. Tears, burns, cuts, or damage due to improper installation, improper use, or improper cleaning agents or maintenance methods.
4. Wear from chairs or other furniture without proper floor protectors will void the warranty. Care should be taken to protect the flooring from damage by using good quality protective feet for chairs, tables, and other furniture. Chair mats may be required under chairs with casters/wheels.
5. Labor costs for installation of original or replacement material.
6. Sale of "seconds," "off goods," or other irregular (non-first-quality) flooring materials. With respect to "seconds" or "off goods," such are sold "as is," and Ecore makes no warranties whatsoever, express or implied with respect thereto, including warranties of merchantability or fitness for a particular purpose.
7. Problems caused by moisture, hydrostatic pressure, or alkali in the sub-floor.
8. Problems caused by uses, maintenance, and installation that are contrary to Ecore Commercial Flooring specifications, recommendations or instructions.
9. Material installed with obvious defects.
10. Damage to flooring products from high heels or spike heels.
11. Damage to flooring products from rubber mats, rubber backed mats, or car tires.
12. Installation of ECOsurfaces products with adhesives other than those recommended by Ecore Commercial Flooring.
13. Fading and/or discoloration resulting from heavy sunlight penetration and ultraviolet ray exposure from direct or glass-filtered sunlight.
14. Material that is not installed and maintained as recommended by Ecore Commercial Flooring.
15. Damage to flooring products from pallet jack and tow-motor traffic.
16. Environments where the product will be exposed to animal fats, vegetable oils, grease, or petroleum based materials. (i.e.: commercial kitchens or auto repair facilities)
17. Premature wear and deterioration from spikes and skate blade exposure.
18. Differences in color between products and photography.
19. Embossing/density deviations between product and samples, photography.

These warranties are in lieu of any other warranty expressed or implied. Ecore Commercial Flooring shall not be liable for any incidental or consequential damages which may result from a defect. Some states do not allow the exclusion or limitation of incidental or consequential damages, so the above limitation or exclusion may not apply to you. These warranties give you specific rights, and you may also have rights which may vary from state to state. To know what your legal rights are in your state, consult your local or state Consumer Affairs Office or your State Attorney General.

For complete and latest warranty information for products within the ECOsurfaces collection please visit [www.ecorecommercialflooring.com](http://www.ecorecommercialflooring.com).





800-258-08431 – [www.ecorecommercialflooring.com](http://www.ecorecommercialflooring.com)

**Manufactured in the U.S.A. by:**

The Ecore logo, consisting of the word "ecore" in a bold, blue, lowercase sans-serif font.

**715 Fountain Ave – Lancaster, PA 17601**

©2015 All designs and colors are copyrighted by Ecore. ECOsurfaces is a registered trademark of Ecore